

CML Tape & Reel Specification

MQSE6

Issue 7
June 2017

Copyright Statement

The copyright of this document is the property of CML Microcircuits (UK) Limited, part of the CML Microsystems plc group. This document must not be copied, reprinted or reproduced in any material form, either wholly or in part, without the written consent of CML Microcircuits (UK) Limited, given by contract or otherwise.

CONTENTS

<u>Section</u>	<u>Page</u>
1. Scope	2
2. Dimensions.....	2
2.1 Tape Width	2
2.2 Carrier Tape Thickness (t)	2
2.3 Pitch of Sprocket Holes (P0)	2
2.4 Diameter of Sprocket Holes (D)	2
2.5 Distance Sprocket Hole Centre to Tape Edge (E)	2
2.6 Distance Sprocket Hole Centre to Centre Hole (F)	2
2.7 Distance between centres if two rows of sprocket holes (S)	2
2.8 Distance between oval hole centres (d)	2
2.9 Radius of oval holes	2
2.10 Dimension (P2)	3
2.11 Embossed Pocket Dimensions (A0 & B0)	3
2.12 Embossed Tape Dimension (K0)	4
2.13 Pitch of Component Pockets (P1)	4
2.14 Outside Dimension of Pocket (B1)	4
2.15 Pocket Centre Hole Diameter (D1)	5
3. Materials	5
4. Polarity & Orientation of Components in Tape	5
5. Fixing of Components in Tape	5
6. Packaging	5
7. History.....	11

1. Scope

The specification relates to the tape packaging of integrated circuits suitable for “surface mount” assembly. It includes only those dimensions that are essential for the purchaser to use this product.

2. Dimensions

2.1 Tape Width

Package style
Q5, Q6, Q7, Q8, QT8 W = 12.0 ± 0.1 mm

D4, D5, D6 W = 16.0 ± 0.1 mm
E1, E2, E3, E4
L4
Q1, Q2, Q3, Q4

D1, D2, D3 W = 24.0 ± 0.1 mm
L1, L2, L7, L8, L9

L6 W = 32.0 ± 0.3 mm

2.2 Carrier Tape Thickness (t)

All package styles t = 0.6 mm max

2.3 Pitch of Sprocket Holes (P₀)

All package styles P₀ = 4.0 ± 0.1 mm

2.4 Diameter of Sprocket Holes (D)

All package styles D = 1.5 + 0.1 – 0.0 mm

2.5 Distance Sprocket Hole Centre to Tape Edge (E)

All package styles E = 1.75 ± 0.1 mm

2.6 Distance Sprocket Hole Centre to Centre Hole (F)

Package style
Q5, Q6, Q7, Q8, QT8 F = 5.5 ± 0.1 mm

D4, D5, D6 F = 7.5 ± 0.1 mm
E1, E2, E3, E4
L4
Q1, Q2, Q3, Q4

D1, D2, D3 F = 11.5 ± 0.1 mm
L1, L2, L7, L8, L9

L6 F = 14.2 ± 0.1 mm

2.7 Distance between centres if two rows of sprocket holes (S)

Package Style
L6 S = 28.4 ± 0.1 mm

2.8 Distance between oval hole centres (d)

Package Style
L6 d = 0.2 ± 0.05 mm

2.9 Radius of oval holes

Package Style
L6 r = 0.75 mm

2.10 Dimension (P2)

All package styles P2 = 2.0 ± 0.1 mm

2.11 Embossed Pocket Dimensions (A0 & B0)

Package style

D1	A0 = 10.9 ± 0.1	mm
	B0 = 18.3 ± 0.1	mm
D2	A0 = 10.9 ± 0.1	mm
	B0 = 15.8 ± 0.1	mm
D3	A0 = 10.9 ± 0.1	mm
	B0 = 13.2 ± 0.1	mm
D4	A0 = 10.9 ± 0.1	mm
	B0 = 10.7 ± 0.1	mm
D5	A0 = 8.2 ± 0.1	mm
	B0 = 8.8 ± 0.1	mm
D6	A0 = 8.4 ± 0.1	mm
	B0 = 10.7 ± 0.1	mm
E1	A0 = 6.8 ± 0.1	mm
	B0 = 10.2 ± 0.1	mm
E2	A0 = 6.95 ± 0.1	mm
	B0 = 8.3 ± 0.1	mm
E3	A0 = 6.8 ± 0.1	mm
	B0 = 6.9 ± 0.1	mm
E4	A0 = 6.8 ± 0.1	mm
	B0 = 5.4 ± 0.1	mm
L1	A0 = 15.8 ± 0.1	mm
	B0 = 15.8 ± 0.1	mm
L2	A0 = 11.5 ± 0.1	mm
	B0 = 11.5 ± 0.1	mm
L4	A0 = 9.3 ± 0.1	mm
	B0 = 9.3 ± 0.1	mm
L6	A0 = 18.0 ± 0.1	mm
	B0 = 18.0 ± 0.1	mm
L7	A0 = 12.5 ± 0.1	mm
	B0 = 12.5 ± 0.1	mm
L8	A0 = 16.5 ± 0.1	mm
	B0 = 16.5 ± 0.1	mm
L9	A0 = 12.5 ± 0.1	mm
	B0 = 12.5 ± 0.1	mm
Q1	A0 = 9.3 ± 0.1	mm
	B0 = 9.3 ± 0.1	mm
Q2	A0 = 8.3 ± 0.1	mm
	B0 = 8.3 ± 0.1	mm
Q3	A0 = 7.25 ± 0.1	mm
	B0 = 7.25 ± 0.1	mm
Q4	A0 = 6.3 ± 0.1	mm
	B0 = 6.3 ± 0.1	mm
Q5, Q8, QT8	A0 = 5.25 ± 0.1	mm
	B0 = 5.25 ± 0.1	mm
Q6, Q7	A0 = 4.35 ± 0.1	mm
	B0 = 4.35 ± 0.1	mm

2.12 Embossed Tape Dimension (K0)

Package style			
D1, D2, D3, D4	K0	=	3.0 ± 0.1 mm
	D5	K0	= 2.5 ± 0.1 mm
	D6	K0	= 2.4 ± 0.1 mm
E1, E2, E3, E4	K0	=	1.6 ± 0.1 mm
	L1	K0	= 2.9 ± 0.1 mm
	L2	K0	= 4.1 ± 0.1 mm
	L6	K0	= 4.9 ± 0.1 mm
L4, L7, L9	K0	=	2.2 ± 0.1 mm
	L8	K0	= 1.9 ± 0.1 mm
	Q1	K0	= 1.1 ± 0.1 mm
	Q2	K0	= 1.1 ± 0.1 mm
	Q3	K0	= 1.1 ± 0.1 mm
	Q4	K0	= 1.1 ± 0.1 mm
Q5, Q8, QT8	K0	=	1.1 ± 0.1 mm
	Q6, Q7	K0	= 1.3 ± 0.1 mm

2.13 Pitch of Component Pockets (P1)

Package style			
E1, E2, E3, E4, Q5, Q6, Q7, Q8, QT8	P1	=	8.0 ± 0.1 mm
D1, D2, D3, D4 D5, D6 L4, Q1, Q2, Q3, Q4	P1	=	12 ± 0.1 mm
L2, L7, L9	P1	=	16 ± 0.1 mm
L1, L8	P1	=	20 ± 0.1 mm
L6	P1	=	24 ± 0.1 mm

2.14 Outside Dimension of Pocket (B1)

Package style			
D1	B1	=	18.9 ± 0.2 mm
D2	B1	=	16.5 ± 0.2 mm
D3	B1	=	13.9 ± 0.2 mm
D4	B1	=	11.4 ± 0.2 mm
D5	B1	=	9.3 ± 0.2 mm
D6	B1	=	11.4 ± 0.2 mm
E1	B1	=	10.9 ± 0.2 mm
E2	B1	=	9.0 ± 0.2 mm
E3	B1	=	7.6 ± 0.2 mm
E4	B1	=	6.3 ± 0.2 mm
L1	B1	=	16.5 ± 0.2 mm
L2	B1	=	12.2 ± 0.2 mm
L4	B1	=	9.9 ± 0.2 mm
L6	B1	=	18.8 ± 0.2 mm
L7	B1	=	13.0 ± 0.2 mm
L8	B1	=	17.1 ± 0.2 mm
L9	B1	=	13.0 ± 0.2 mm
Q1	B1	=	10.4 ± 0.2 mm
Q2	B1	=	9.4 ± 0.2 mm
Q3	B1	=	8.4 ± 0.2 mm
Q4	B1	=	7.4 ± 0.2 mm

Q5, Q8, QT8	B1 =	6.4 ± 0.2	mm
Q6, Q7	B1 =	5.4 ± 0.2	mm

2.15 Pocket Centre Hole Diameter (D1)

Package style	
D1, D2, D3, D4, D5, D6	
E1, E2, E3, E4	
L1, L2, L4, L6, L7, L8, L9	D1 = 1.5mm Minimum
Q1, Q2, Q3, Q4, Q5, Q6, Q7, Q8, QT8	

3. Materials

- 3.1. Carrier tape to be made of a conductive grade of polystyrene.
- 3.2. Conductive grade polycarbonate is also an approved carrier tape material and may be used under certain circumstances.
- 3.3. Temperature sealed cover tape is an anti static grade of PET/PE film.

4. Polarity & Orientation of Components in Tape

- 4.1. All components are placed such that pin 1 is adjacent to the sprocket holes (See figures 6a, 6b, 6c, 6d, 6e & 6f)
- 4.2. The mounting side of the component is oriented to the bottom side of the tape (See Figure 2).

5. Fixing of Components in Tape

- 5.1. The cover tape shall not cover the sprocket holes in the carrier tape
- 5.2. Tapes in adjacent layers shall not stick together in the packing.
- 5.3. The adhesive of the cover tape shall not adversely affect the mechanical and electrical characteristics and the marking of the component.
- 5.4. Components will not stick to the carrier tape or the cover tape.
- 5.5. The tapes shall be suitable to withstand storage of the taped components without danger of migration of the terminations or the giving off of vapours, which would impair soldering or deteriorate the component properties or termination by chemical action.
- 5.6. When the tape is bent with a minimum radius (See Figure 5), the tape shall not be damaged and the components shall remain in their position and orientation in the tape.
- 5.7. The peel strength of the cover tape shall be 60 + 40/-30 grams measured at 175° –180° with respect to the carrier tape along its longitudinal axis. The peel speed shall be 300mm/min.
- 5.8. After baking at 50°C for 60 hours or storage in ideal conditions for three months the peel strength shall remain within the specified limits.

6. Packaging

- 6.1. The tape will be wound on anti-static high impact polystyrene reels (See Figure 4).

6.1.1 Dimensions (in millimetres)

W Tape Width	A Reel Dia.	C Centre Hole Dia.	N Hub Outer Dia.	W1 Inside Cheek Width	W2 Outside Cheek Width	Product types
12	330	13	101	12.8	17.3	All
16	330	13	101	16.8	21.3	All
24	330	13	101	24.8	29.3	All except L8
24	330	13	175	24.8	29.3	L8 only
32	330	13	101	32.8	37.3	All

- 6.2. There will be a leader of a minimum of 400 mm of covered empty compartments.
- 6.3. In no case shall there be two or more consecutive components missing. The maximum number of missing components per reel shall be one, or 0.1% whichever is greater.
- 6.4. At the end of the tape, there will be a trailer of a minimum of 160 mm of sealed empty pockets.
- 6.5. The tape shall release from the reel hub as the last portion of the carrier tape unwinds from the reel.
- 6.6. Standard number of components on a reel:

Package style	=	Minimum Quantity	Maximum Quantity
D1	=	1,000	1,500
D2	=	1,000	1,500
D3	=	1,000	1,500
D4	=	1,000	1,500
D5	=	1,000	-
D6	=	1,000	-
E1	=	1,000	3,000
E2	=	1,000	3,000
E3	=	1,000	3,000
E4	=	1,000	3,000
L1	=	500	-
L2	=	500	-
L4	=	1,000	-
L6	=	500	500
L7	=	1,000	-
L8	=	1,000	-
L9	=	1,000	-
Q1	=	1,000	3,500
Q2	=	1,000	3,500
Q3	=	1,000	3,500
Q4	=	1,000	3,500
Q5	=	1,000	5,000
Q6	=	1,000	5,000
Q7	=	1,000	5,000
Q8	=	1,000	5,000
QT8	=	1,000	5,000

- 6.7. The tape will be prevented from unreeling by winding a tape around the reel and fixing with adhesive tape.
- 6.8. All reels will display:
1. Device Type
 2. Quantity on reel
 3. A CML serial number/bar code.
 4. The date reel sealed.
 5. A static hazard warning label
- 6.9. Reels are packed in an anti-static bubble bag and a cardboard box (with appropriate labelling).
- 6.10. Ideal storage conditions for sealed tape are 15°C to 20°C with a relative humidity less than 60%.
- 6.11. Shelf life of sealed tape when stored in ideal conditions will be in excess of six months.

Package Types: D1 - D6, E1 - E4, L1- L4, L7 - L9, Q1 - QT8

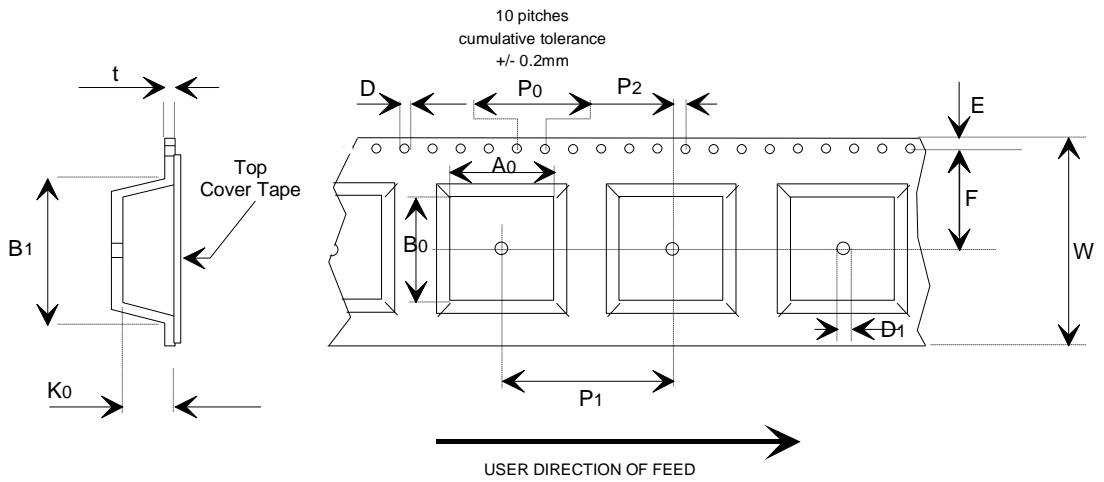

Figure 1a

Package Type: L6

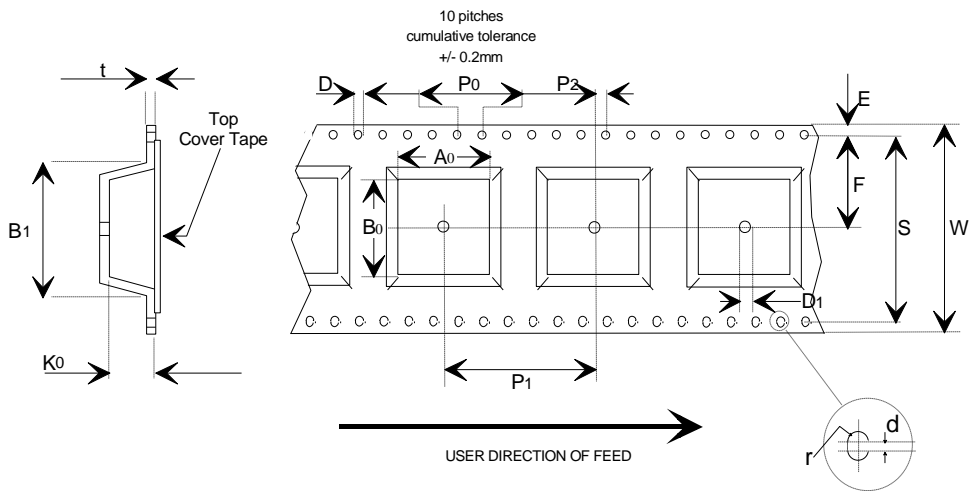
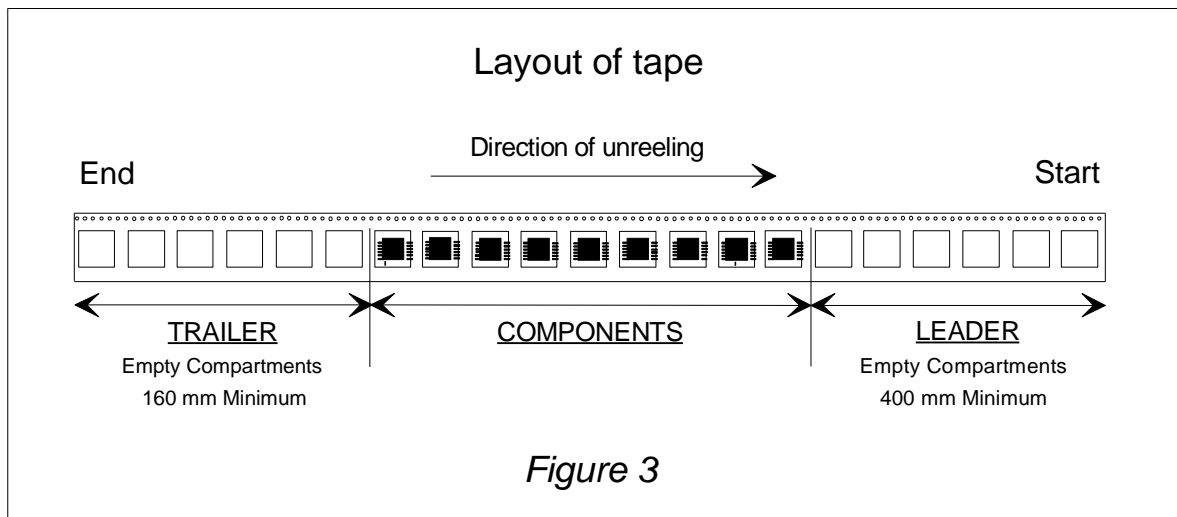
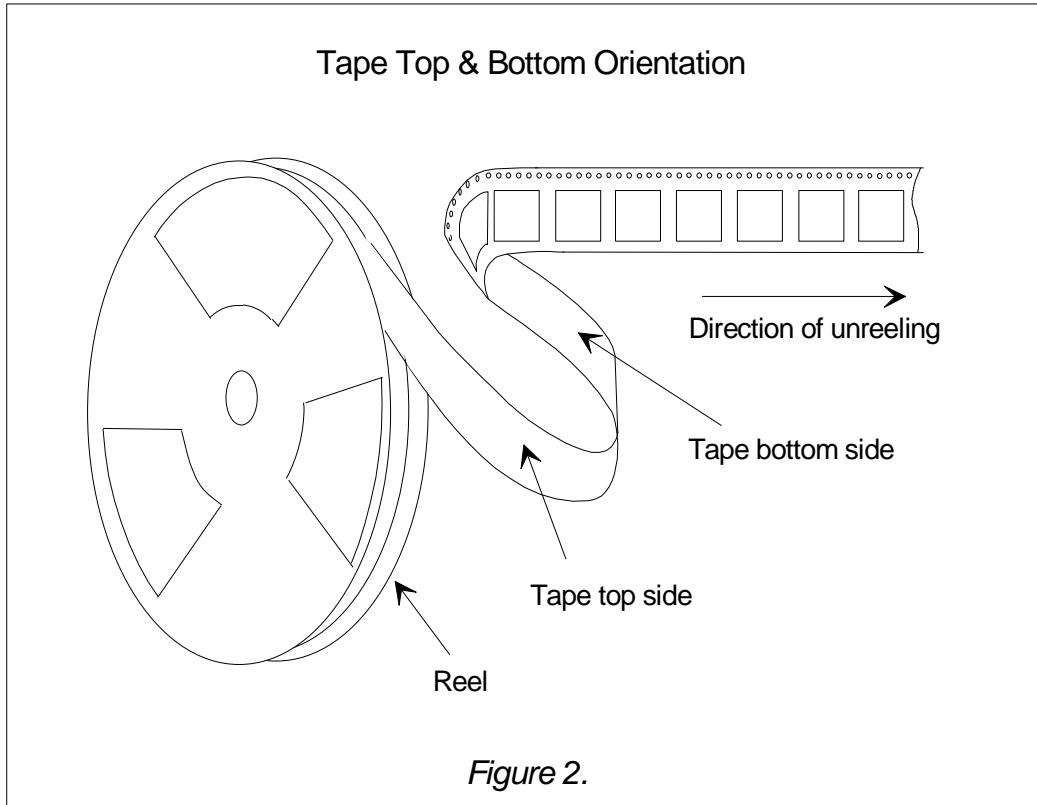

Figure 1b



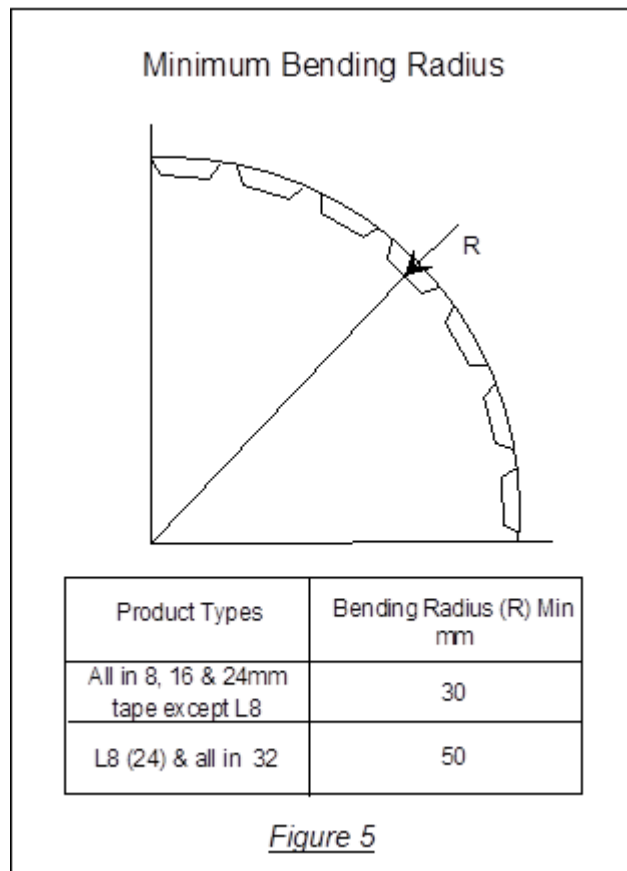
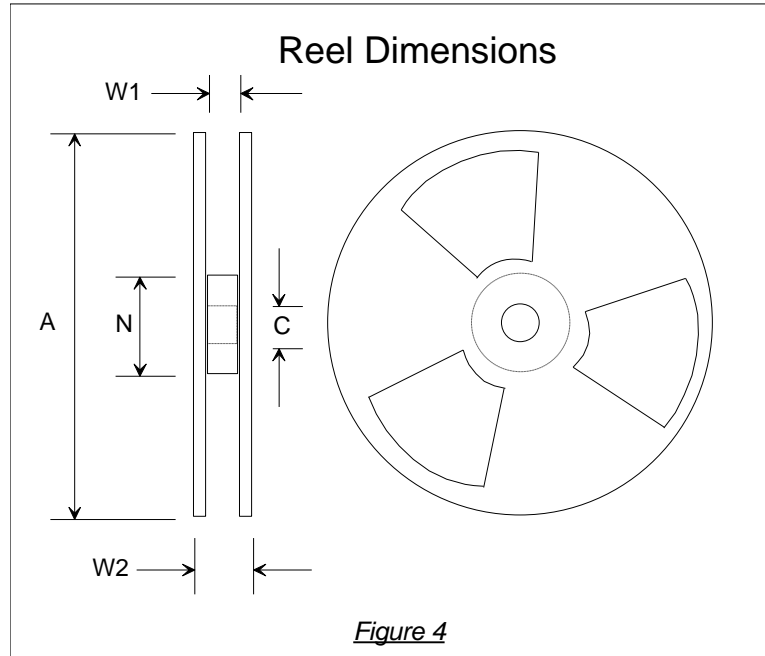

Figure 6a.

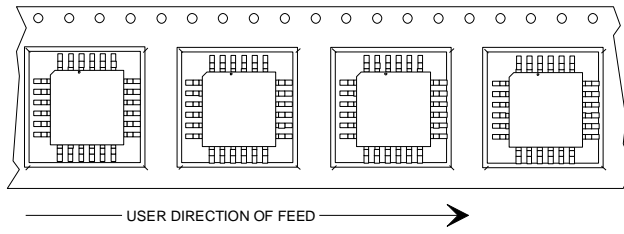

Figure 6b

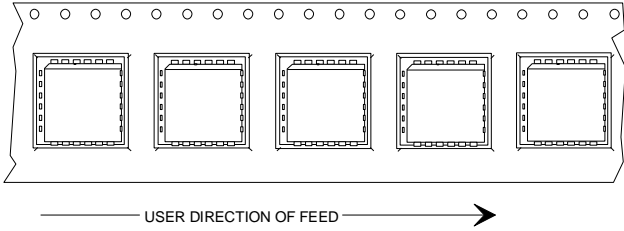

Figure 6c

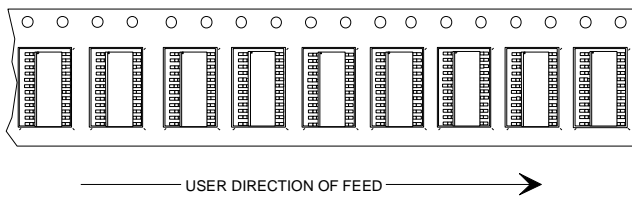

Figure 6d.

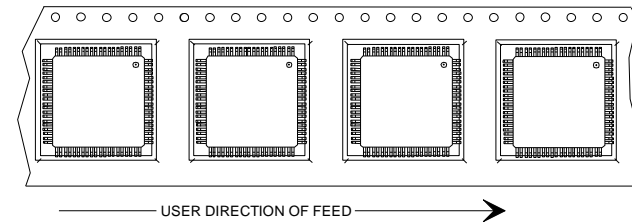

Figure 6e.

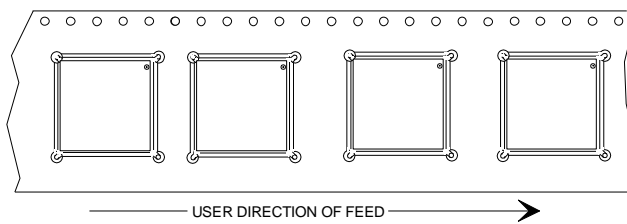

Figure 6f.

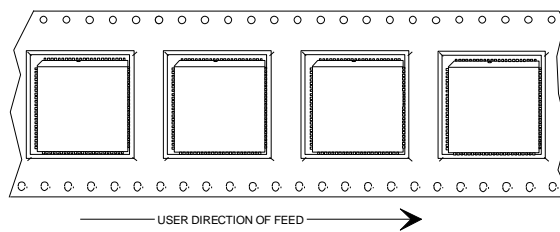

Figure 6. Component Orientation

7. History

Version	Changes	Date
1	Initial release	March 2002
2	S1 package deleted Drawing 1a removed & 6d modified to remove second row of index holes L8 package included Specification style and layout changed.	April 2004
3	Section 5.7: Pull strength speed changed from 240 mm to 300 mm per minute	September 2005
4	Q1-Q5 (incl) data added. Figure 6 updated to include QFN (6e) Pressure sensitive cover tape removed	November 2006
5	L6 package data included. Fig 6 updated to include 44 Lead PLCC (6f)	May 2007
6	Change of Process Owner Q6 and Q7 packages included	July 2014
7	Q8 and QT8 packages added. L3 and M1 packages removed. Change of Managing Director. 5.7:- Peel strength was 60 ± 40 grams, now $60 +40/-30$ grams. Table 6.1.1:- Tape width was quoted as 8mm in error, should have been 12mm. This affected values for W, W ₁ and W ₂ 6.7:- "paper" deleted as it's not always a paper tape used.	June 2017



CML Microcircuits

COMMUNICATION SEMICONDUCTORS

United Kingdom tel: +44 (0) 1621 875500

Singapore tel: +65 62888129

United States tel: +1 336 744 5050
800 638 5577

email: sales@cmlmicro.com
techsupport@cmlmicro.com

email: sg.sales@cmlmicro.com
sg.techsupport@cmlmicro.com

email: us.sales@cmlmicro.com
us.techsupport@cmlmicro.com

www.cmlmicro.com