

DIM.	MIN.	TYP.	MAX.
* A		9.00 BSC	
* B		9.00 BSC	
C	0.80	0.90	1.00
F	7.00		7.80
G	7.00		7.80
H	0.00		0.05
J	0.18	0.25	0.30
K	0.20		
L	0.30	0.40	0.50
L1	0		0.15
P		0.50	
T		0.20	

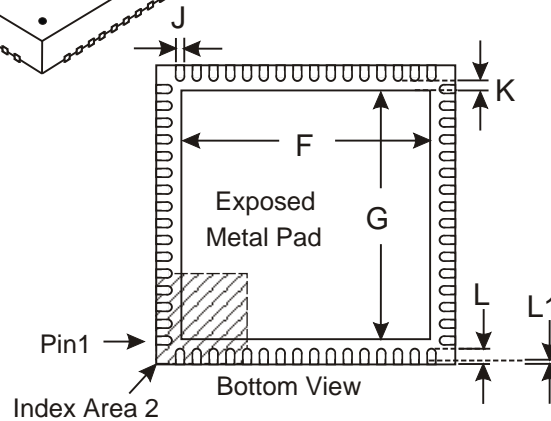
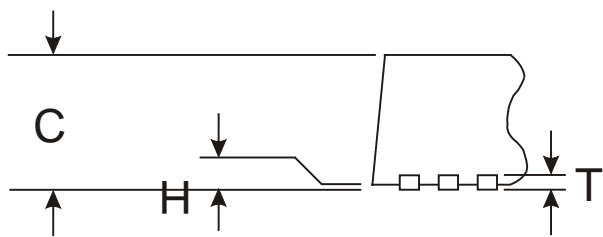
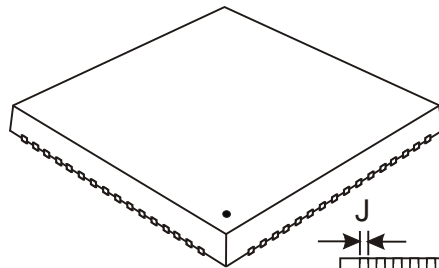

NOTE :  
 \* A & B are reference data and do not include mold deflash or protrusions.

All dimensions in mm  
 Angles are in degrees

Index Area 1

Index Area 2



Index Area 1 is located directly above Index Area 2

Depending on the method of lead termination at the edge of the package, pull back (L1) may be present.

L minus L1 to be equal to, or greater than 0.3mm

The underside of the package has an exposed metal pad which should ideally be soldered to the pcb to enhance the thermal conductivity and mechanical strength of the package fixing. Where advised, an electrical connection to this metal pad may also be required

TITLE		DRAWING No. Q1	
64-Lead-VQFN Package		D'WN	S.D.F
		© C.M.L. 2008	
		SHEET	OF 1
		ISSUE	8